



VB1 Plus Vacuum Circuit Breaker  
User Manual



## Caution!

Please read this manual carefully before installing and using the circuit breaker:

The installation and use of circuit breakers must comply with the requirements of this manual.

Circuit breaker should be used in accordance with the normal indoor environmental conditions.

Any operation and maintenance of the circuit breaker should be carried out by professional trained full-time electrical personnel.

It is forbidden to operate the circuit breaker beyond its rated parameters.

Attention must be paid to any identification of circuit breakers.

It is necessary to ensure the applicability and safety of interlocking conditions and working procedures of circuit breakers.

It is not allowed to carry out maintenance work when the switch cabinet and secondary control circuit are charged.

It must be ensured that the circuit breaker is not impacted by any external force, otherwise the equipment will be damaged.

Any illegal operation of the circuit breaker may damage the equipment and even cause serious accidents.

This manual should be placed in a convenient place.

Professional personnel should be responsible for the safety management of circuit breakers.

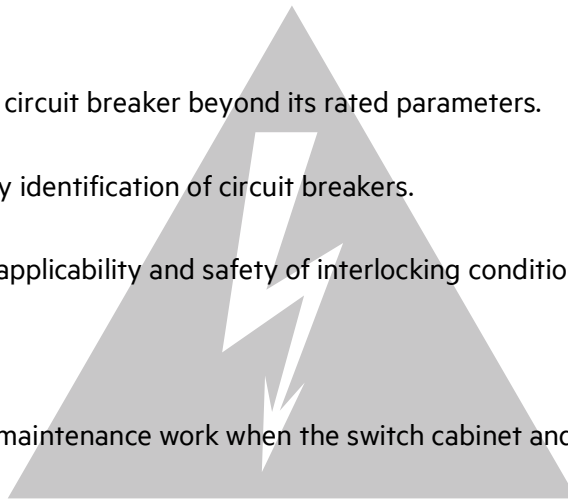

# Contents

1. Overview .....	1
2. Structural principle.....	2
3. Technical parameter .....	5
4. Dimensions .....	6
5. Electrical schematic diagram.....	8
6. Installation, commissioning and operation.....	8
7. Maintenance.....	9
8. Transportation and storage .....	11
9. Random documents.....	11
10. Spare parts.....	12

## 1. Overview

### 1-1 General:

VB1 Plus vacuum circuit breaker (hereinafter referred to as circuit breaker) is suitable for indoor switchgear components with air insulation, and can be used to replace the original VB1 circuit breaker switchgear in AC power systems with a maximum rated voltage of 15kV.

### 1-2 General provisions:

VB1 Plus breaker complies with the following standards:

GB/T 1984	High-voltage alternating-current circuit-breakers
IEC 62271-100	High-voltage switchgear and controlgear - Part 100: Alternating current circuit-breakers
IEC 60694	Common specifications for high-voltage switchgear and controlgear standards
IEEE C37.59-2018	IEEE standard for requirements for conversion of power switchgear equipment - redline
IEEE C37.04-2018	IEEE standard for ratings and requirements for AC high-voltage circuit breakers with rated maximum voltage above 1000 V
IEEE C37.06-2017	IEEE recommended practice for preferred ratings for high-voltage (>1000 volts) AC circuit breakers designated definite purpose for fast transient recovery voltage rise times
IEEE C37.20.2-2015	IEEE standard for metal-clad switchgear
IEEE C37.09-2018	IEEE standard test procedures for AC high-voltage circuit breakers with rated maximum voltage above 1000 V
IEEE C37.100	IEEE standard for common requirements for high-voltage power switchgear rated above 1000 V
DL/T 403	HV vacuum circuit-breaker for rated voltage 12kV to 40.5kV

### 1-3 Normal operating conditions:

Ambient temperature

Maximum temperature: + 40°C

Minimum temperature: - 25°C

Maximum daily average temperature: + 35°C

Ambient humidity

Daily average relative humidity: ≤95%

Monthly average relative humidity: ≤90%;

Daily average saturated vapor pressure: ≤2.2×10<sup>-3</sup> Mpa

Monthly average saturated vapor pressure: ≤1.8×10<sup>-3</sup> Mpa

Altitude: ≤ 1000m, conventional products can be used below 1000m above sea level, and high-altitude products need to be noted when ordering.

Earthquake intensity: No higher than Level 8

Others: no inflammable and explosion hazard, no chemical corrosive gas and no violent vibration.

Note: in case of different use environment or other special requirements, it is necessary to consult with the manufacturer.

## 2. Structural principle

### 2-1 Main structure

The conductive circuit of the circuit breaker is a fixed structure, and the conductive circuit is set in the insulating parts. This structure can effectively prevent the influence of external factors such as external force impact and pollution environment on the vacuum interrupter. The conductive circuit of the circuit breaker is installed at the back of the mechanism box and connected with the mechanism as a whole.

Primary circuit current route: when breaker is at the closing position, current flow from the upper terminal to the upper bracket, which is fixed in the arc quenching chamber, then into the vacuum interrupter contacts, the movable contact, and connection of conductive clips, soft connection, to the lower terminal, the insulating pull rod and the internal disc spring pass through the connecting rod of the circuit breaker to complete the operation movement of the circuit breaker and keep the contact.

### 2-2 Operating mechanism

The operating mechanism of the circuit breaker is a spring energy storage mechanism. There are closing unit, opening unit composed of one or several coils, auxiliary switch, indicating device and other components in the mechanism box; the front is provided with closing and opening button, manual energy storage operation hole, spring energy storage status indicator board and closing and opening indicator board.

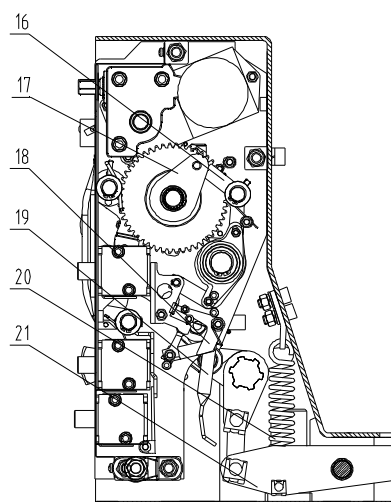
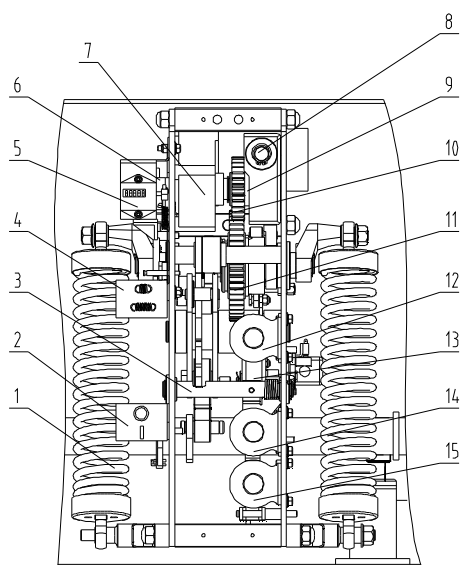

- |                                  |                              |   |
|----------------------------------|------------------------------|---|
| 1. Closing spring                | 2. closing/opening indicator | 3. opening latch                              |
| 4. charging indicator            | 5. counter                   | 6. micro-switch                               |
| 7. charging motor                | 8. manual charging shaft     | 9. motor output shaft                         |
| 10. small gear                   | 11. large gear               | 12. closing coil                              |
| 13. closing plate                | 14. opening coil             | 15. over-current coil/secondary tripping coil |
| 16. energy storage keeping block | 17. energy storage latch     | 18. closing interlock block                   |
| 19. handcart interlock block     | 20. opening spring           | 21. output arm                                |

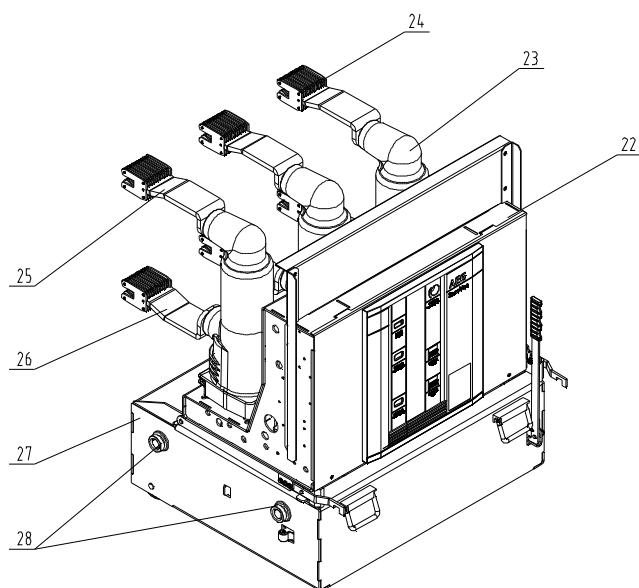

- 22. Vacuum Circuit Breaker
- 23. Embedded pole
- 24. contact
- 25. Uppercontact arm
- 26. Lower contact arm
- 27. Chassis
- 28. contact roller

## 2-2-1 Energy storage

The energy required for closing the circuit breaker is provided by the closing spring. Energy storage can be done either by motor or by hand with energy storage handle.

Energy storage operation: it is carried out by the energy storage motor 7 fixed on the frame or by inserting the energy storage handle into the manual energy storage shaft 8 and shaking it clockwise. The gear system is driven by motor output shaft 9 for electric energy storage, and the gear system is driven by manual energy storage shaft 8 for manual energy storage. When the small gear rotates, it drives the big gear to move together, thus pulling the energy storage spring to store energy. When the energy storage position is reached, the energy storage holding block is supported by the energy storage holding block to separate the clutch and maintain the energy storage position. The energy storage indicator board shows the tension state of the tension spring, and the energy storage is completed. The micro switch cuts off the power supply of the energy storage motor, and the circuit breaker is in the closing ready state.

## 2-2-2 Closing

During the closing process, whether manually pressing the "closing" button or remote operation to make the closing coil 12 act, the energy storage holding device can be turned away from the energy storage holding block. Under the action of the closing spring force, the cam drives the cam to rotate, and

the cam drives the connecting rod mechanism to drive the insulating rod 23 and the moving contact of the arc extinguishing chamber to close.

After the closing action is completed, the opening holding switch and the opening half shaft are kept in the buckle state. At the same time, the energy storage indicator board and auxiliary switch are reset, and the motor power supply circuit is connected. If the external power supply is also connected, it will enter the energy storage state again, and the connecting rod will pull the on / off indicator to indicate the position of " | ", at the same time, pull the counter to realize counting, and drive the connecting rod to pull the spindle to drive the auxiliary switch to switch.

Note: when the circuit breaker is in the closing state, or the closing locking device is selected but the external power supply is not connected, and the handcart type circuit breaker is in the process of propulsion, the closing operation cannot be carried out.

### 2-2-3 Opening

It can not only press the "opening" button, but also connect the external power supply to make the opening coil or over-current coil act, so that the opening holding switch and the opening half axis are unlocked to realize the opening operation. The energy stored by the contact spring and the opening spring 25 separates the dynamic and static contacts of the arc extinguishing chamber 21. In the later stage of the opening process, the hydraulic buffer absorbs the residual energy and limits the opening position.

Pull the "O" connecting rod to switch off the switch.

### 2-2-4 Undervoltage protection function

When the secondary control voltage is less than or equal to 90% of the rated voltage, the undervoltage module must start to store energy for components and enter the holding state; when the secondary control voltage drops to 65% of the rated voltage, the energy of the undervoltage module is released to the opening coil of the circuit breaker to release the opening holding switch and the opening half shaft So as to realize the opening operation.

### 2-3 Anti misoperation interlock

The circuit breaker can provide perfect anti misoperation function

1. After the closing operation of the circuit breaker is completed, the closing interlocking board 18 rotates against the closing board 13, and it cannot be closed again when the circuit breaker is not opened.

2. After closing the circuit breaker, if the closing electric signal is not removed in time, the internal anti tripping controller of the circuit breaker will cut off the closing circuit to prevent multiple reclosing.

3. When the handcart type circuit breaker fails to reach the test position or working position, the handcart interlocking board 19 shall buckle the closing board and cut off the closing circuit to prevent the circuit breaker from entering the load area in the closing state.

4. After the handcart type circuit breaker is closed in the working position or test position, the trolley will not be able to move if the roller presses the pushing mechanism, so as to prevent pulling out or pushing the load area in the closing state.

5. If electrical closing locking is selected, manual closing operation is prevented when the secondary control power supply is not connected.

### 3. Technical parameter

#### 3-1 Main technical parameter

No.	Item	Unit	Value	
1	Rated voltage	kV	12	15
2	Rated normal current	A	1200/1250/2000	1200/1250/2000
3	Rated power frequency withstand voltage (1 min)	kV	42/48	42/48
4	Rated lightning impulse withstand voltage		75/85	95/105
5	Rated frequency	Hz	50/60	50/60
6	Rated short-circuit breaking current	kA	31.5 40	31.5 40
7	Rated short-time withstand current(2s)		31.5 40	31.5 40
8	Rated peak withstand current	kA	80 100	82 104
9	Rated short-circuit making current		80 100	82 104
10	Rated operation procedure		O-0.3s-CO-180s-CO	O-0.3s-CO-180s-CO
11	Contact distance	mm	9.0±1.0	9.0±1.0
12	Contact travel		3.5±0.5	3.5±0.5
13	Average closing speed	m/s	0.4~0.8	0.4~0.8
14	Average opening speed		0.9~1.3	0.9~1.3
15	Closing time (rated voltage)	ms	30~70	30~70
16	Opening time (rated voltage)		20~50	20~50
17	Closing bounce time	ms	≤2	≤2
18	Three-phase opening/closing		≤2	≤2
19	Main loop resistance	μΩ	≤45 (1200/1250A) ; ≤40 (2000A)	≤45 (1200/1250A) ; ≤40 (2000A)
20	Energy storage time	s	≤10	≤10
21	Classification	class	E2-M2-C2	E2-M2-C2

### 3-3 Technical parameters of operating mechanism and locking electromagnet

Rate voltage (V)	Energy storage motor (A)	Closing coil (A)	Opening coil (A)	Lockout electromagnet (mA)
DC 110	2.0	2.2	2.2	35
DC 220	1.0	1.3	1.3	20

## 4. Dimensions

The overall dimensions are shown in the figure below.

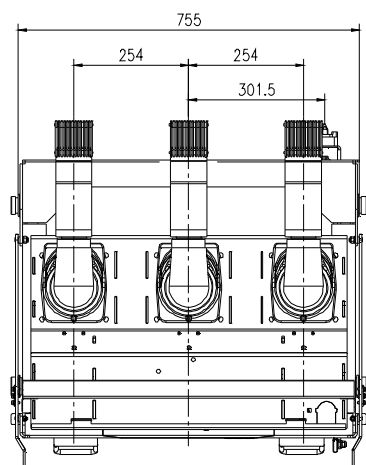
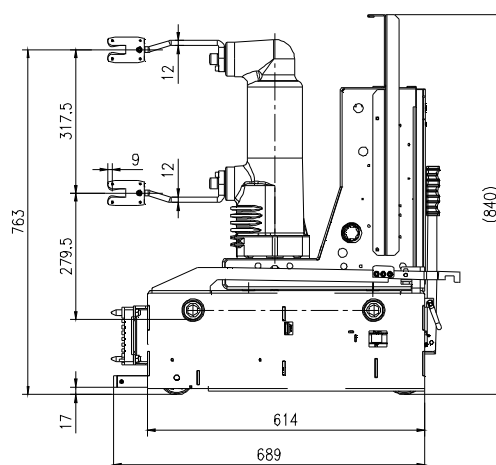
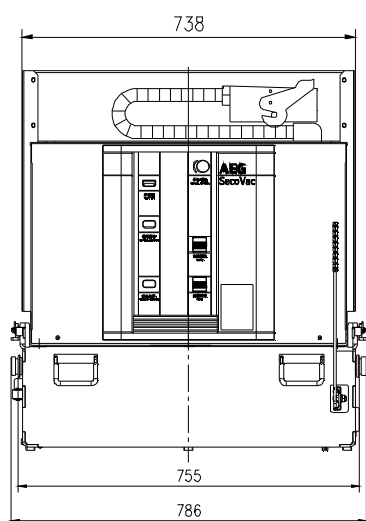

Specification
1200A/25~31.5kA
1250A/25~31.5kA

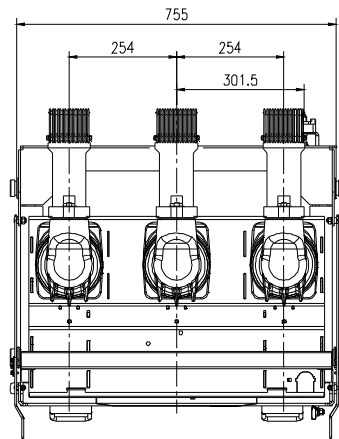
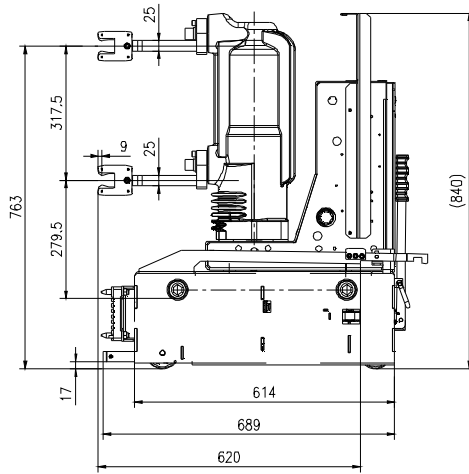
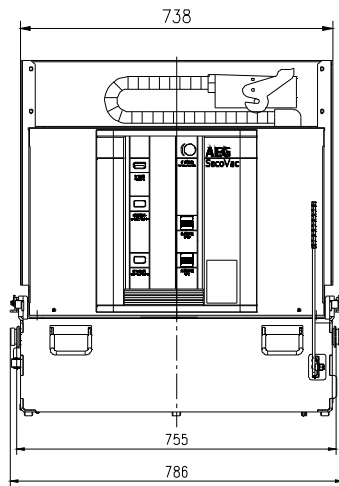

Specification
1200A/40kA
1250A/40kA
2000A/31.5~40kA

## 5. Electrical schematic diagram

Conventional circuit breaker products are equipped with anti-trip circuit, but according to the needs of users, the anti-tripping circuit can be removed.

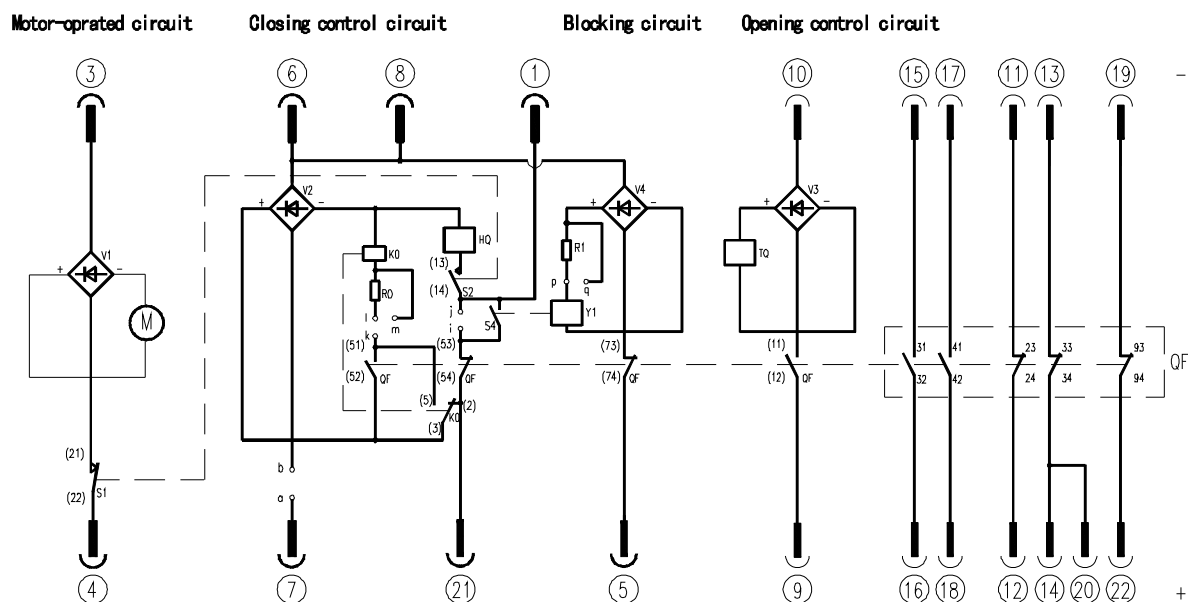

Option	Jumper wires	a-b	l-j	l-k
■ Anti-pumping relay	■ Blocking coil	■	□	■
	□ Blocking coil	■	■	■
□ Anti-pumping relay	■ Blocking coil	■	□	□
	□ Blocking coil	■	■	□

Option	Jumper wires	p-q	m-l
AC/DC 220V	■	□	□
AC/DC 110V	■	■	■

### Remarks:

1. Shown with the stored-energy spring in the discharged, the breaker in open and test position.
2. The light grey terminal must be the same pole in DC control voltage.

S4: Auxiliary switch for blocking coil	HQ: Closing coil	M: Energy-storage motor
S1/S3: Energy storage position switch	TQ: Opening coil	OF: Auxiliary switch of closing/opening operation
K0: Anti-pumping relay(optional)	R0/R1: Resistance	V1/V4: Rectifier

## 6. Installation, commissioning and operation

6-1 When the circuit breaker is lifted from the packing box, the hook shall be hung on the lifting position with lifting mark on the circuit breaker. When moving, the upper and lower outlet arms shall not be stressed, and the circuit breaker shall not be subject to large impact and vibration.

6-2 The circuit breaker installed in the switch cabinet shall not be subject to tension or deformation, and the bolt at the bottom mounting point shall be added with disc spring gasket. When connecting the main terminal, the main terminal shall not be subject to permanent tension and pressure (such as the bus bar). When connecting the bus, bolts with strength  $\geq 8.8$  and disc spring are used to fasten the bus.

6-3 In case of problems in operation, determine the causes according to the table below. If it can't be solved, please contact the manufacturer. Do not disassemble the circuit breaker by yourself.

No.	Fault phenomena	Reasons
1	Failure to closing	1. The breaker is in the closing position state
		2. The handcart does not fully come into operation position or test position
		3. The closing locking device is employed and the auxiliary supply is unconnected or lower than the specifications
		4. secondary circuit is incorrect
2	The handcart cannot be pushed in or pulled out	1 The breaker is in the closing position state
		2 The pushing- handle is not fully inserted into the pushing hole.
		3. The pushing mechanism is not fully placed at the test position, so that the clapper cannot be unlocked with the cabinet body
		4. The cabinet body earthing interlocking is not released

6-4 The commissioning and operation work shall be carried out by specially trained personnel who have a detailed understanding of the performance of the circuit breaker. The corresponding protection and prevention measures must be considered in the work.

One of the preconditions for trouble free operation is to use the circuit breaker under normal working conditions according to the corresponding provisions of GB/T 1984 and IEC 60694 standards.

- check the circuit breaker for damage or any other harmful environmental impact. If there is such a phenomenon, it should be eliminated before power on to restore to normal working conditions.
- Remove dirt, especially on the surface of insulating parts. These may be due to contamination during transportation or storage, which may affect the insulation performance of the product.
- check the connection status of primary circuit contact, secondary circuit connection and grounding body.
- Manual operation test.

## 7. Maintenance

Maintenance must be carried out by AEG personnel or the user's personnel who are familiar with the equipment and have been trained and qualified. If the maintenance is carried out by the user's personnel, the user shall be responsible for the consequences of the repair.

7-1 During normal use, the circuit breaker is free of maintenance. Because the circuit breaker has the characteristics of simple structure and durability, it has a long service life. The maintenance work is related to the wear and aging of parts. In order to make the circuit breaker work reliably, the interval time and range of maintenance work needed to be carried out will depend on the influence of working environment, operation times, operation time and short circuit current breaking times and other factors.

7-2 Before maintenance, all auxiliary power supply must be disconnected and there is no danger of power transmission again. The circuit breaker itself is open and the spring is not stored energy. In order to

prevent accidents, special care should be taken in the operation mechanism.

7-3 Disassembly and replacement of circuit breaker parts shall be carried out by AEG personnel or corresponding trained personnel, especially during reassembly, necessary adjustment shall be made.

#### 7-4 Maintenance of circuit breaker

a. The operation structure shall be inspected when the circuit breaker has been operated for 5 years (from the day when the new equipment is put into operation) or when the circuit breaker operates for the specified times (4000 times for the circuit breaker with 31.5kA, and 2500 times for the circuit breaker with 40kA):

- Cut off the energy storage power supply and operate the circuit breaker to close and open once to release energy.
- Check the grease condition of rolling or sliding bearing surface.
- Check the correctness of each component function during electrical and mechanical action.
- Do a comprehensive appearance inspection.

b. The operation structure shall be maintained after 10 years of operation (calculated from the day when the new equipment is put into operation) or the operation times of the circuit breaker (31.5 kA circuit breaker for 8000 times, 40 kA circuit breaker for 5000 times):

- Cut off the energy storage power supply and operate the circuit breaker to close and open once to release energy.
- Re apply grease to supporting shaft, rolling and sliding bearing.
- Check the correctness of each component function during electrical and mechanical action.
- Check the condition or looseness of fasteners installed at connecting rod, crank arm and supporting rod.
- During maintenance, it is important to check the parts which are subjected to high stress during operation.

In case of replacement of parts, all fasteners shall be replaced.

Comprehensive review of operating mechanism.

7-5 After the circuit breaker has been running for about 5 years or when the operating mechanism is under maintenance, the circuit breaker body should also be inspected. Especially when inspecting the appearance, it is also necessary to check the contamination, damp and corrosion of the equipment surface. Clean the dust on the surface of insulating parts with dry cloth, and then wipe all kinds of dirt with silk cloth with household alkaline cleaning agent or safety cleaner (pay attention to whether the detergent used is applicable to plastic and synthetic rubber materials), and do not use carbon tetrachloride or trichloroethylene to wipe.

The minimum interval of the above inspection work shall be less than 5 years for the switchgear operating in some special use occasions or under harmful environmental conditions (such as in the environment with high pollution and heavy corrosive gas).

## **8. Transportation and storage**

8-1 When the product is transported, the circuit breaker shall be placed in a closed packing box without energy storage, and a proper amount of desiccant shall be built in. The circuit breaker shall be protected with plastic film to prevent water penetration during loading and unloading and dust intrusion during storage.

8-2 The following tools shall be used to load and unload the packing box

- Crane
- Forklift
- Driving

8-3 Pay attention to the following items during transportation:

- Avoid shocks
- Avoid other destructive mechanical forces
- The lifting appliance should not be hooked on the circuit breaker body or operating mechanism. It should be hooked at the lifting position with lifting mark.

8-4 The circuit breaker shall be stored in the state of opening of operating mechanism and energy storage spring without energy storage.

Basic storage requirements

- The dry and well ventilated storage room shall meet the relevant provisions of GB /T 1984 and IEC 60694.
- The temperature of the storage room shall not be lower than -25 ° C.
- Do not disassemble or damage the package. Cover with a protective light covering and maintain adequate ventilation.
- Regularly check whether there is condensation phenomenon and other conditions not suitable for storage requirements.

## **9. Random documents**

- a. Product certificate
- b. Factory inspection report
- c. Packing list

## 10. Spare parts

When the user needs, the spare parts can be determined according to the following list, and put forward when ordering, so as to meet the needs.

<b>Order number (SAP)</b>	<b>Product model</b>
26490381	Closing locking electromagnet 110V (S4)
26490780	Closing locking electromagnet 220V (S4)
26490463	Closing/opening control circuit board (please mention: operation voltage, whether there is anti-tripping, whether there is locking)
26490092	Closing/opening auxiliary switch (QF)
26490580	Energy storage position switch (S1, S2, S3)
26400055	Closing/Opening coil (110V)
26400054	Closing/Opening coil (220V)
26490375	12kV breaker energy-saving motor (110V)
26490359	12kV breaker energy-saving motor (220V)
26490349	Pushing handle for withdrawable-type breaker
26490365	Mechanism energy-saving handle

# AEG

Website: [www.aeg-imc.com](http://www.aeg-imc.com)

Hotline: 400-820-5234

The manual is for reference only, we reserve the right to include modifications.

Version number: 2026IM3801

AEG is a registered trademark used under license from AB Electrolux (publ).

