



VB1 Plus 真空断路器

VB1 Plus Vacuum Circuit Breaker

用户手册

User Manual

注意事项!

在断路器安装使用前请仔细阅读本使用手册：

断路器的安装和使用必须遵守本手册的要求。

断路器的使用场合应符合户内正常的环境使用条件。

对断路器的任何操作和维护都应该由经过专业培训的专职电气人员进行。

禁止把断路器置于超出其额定参数的情况下运行。

必须注意断路器的任何标识。

必须保证断路器的联锁条件和工作规程的适用性和安全性。

不能在开关柜及二次控制回路带电的情况下从事检修工作。

必须确保断路器不受任何外力的冲击，否则将损坏设备。

对断路器的任何违规操作均可能损坏设备，甚至引起严重事故。

应把本手册放在可以方便拿到的地方。

应由专业人员负责断路器的安全管理。

目录

1.概述.....	1
2.结构原理.....	1
3.技术参数.....	4
4.外形尺寸.....	5
5.电气原理图.....	7
6.安装、调试与操作.....	7
7.维护与保养.....	8
8.运输与储存.....	9
9.随机文件.....	10
10.备品备件.....	10

1.概述

1-1 总则:

VB1 Plus 真空断路器 (以下简称断路器) 适用于空气绝缘的户内开关设备元件, 最大额定电压达 15kV的交流电力系统中, 可用于替换原有VB1断路器开关设备。

1-2 引用总则:

VB1 Plus 断路器符合以下标准:

GB/T 1984	《高压交流断路器》
IEC 62271-100	《高压交流断路器》
IEC 60694	《高压开关设备和控制设备标准的共用技术要求》
IEEE C37.59-2018	《IEEE 电力开关设备转换要求标准》
IEEE C37.04-2018	《IEEE 额定最大电压高于 1000V 的交流高压断路器额定值和要求标准》
IEEE C37.06-2017	《IEEE 快速瞬态恢复电压上升时间专用高压 (> 1000 伏) 交流断路器的推荐额定值》
IEEE C37.20.2-2015	《IEEE 金属铠装开关设备标准》
IEEE C37.09-2018	《额定最大电压高于 1000V 的交流高压断路器的 IEEE 标准试验程序》
IEEE C37.100	《IEEE 电力开关设备标准定义》
DL/T 403	《12kV~40.5kV高压真空断路器订货技术条件》

1-3 正常使用条件:

环境温度

最高温度: +40°C

最低温度: -25°C

最高日平均温度: + 35°C

环境湿度

日平均相对湿度: ≤95%

月平均相对湿度: ≤90%

日平均饱和蒸汽压: ≤2.2X10⁻³MPa

月平均饱和蒸汽压: ≤1.8X10⁻³MPa

海拔高度: ≤1000m, 常规产品满足海拔1000m以下使用, 高海拔产品需在订货时注明。

地震强度: ≤8度

其他: 使用场所无易燃和爆炸危险, 无化学腐蚀性气体以及无剧烈震动。

注: 当使用环境不同或有其它特殊要求时需与制造厂协商。

2.结构原理

2-1 主体结构

断路器的导电回路为固封式结构, 导电回路设置在绝缘件内, 这种结构能有效地防止包括外力冲击、

污秽环境等外界因素对真空灭弧室的影响。断路器导电回路安装在机构箱后部，与机构连成一个整体。

断路器在合闸位置时主回路电流路径为：由固封极柱上触臂，到真空灭弧室内部静触头，经动触头及其连接的导电夹、软连接，至极柱下触臂，由绝缘拉杆与内部碟形弹簧经过断路器连杆来完成断路器的操作运动及保持触头接触。

2-2 操作机构

断路器操作机构为弹簧储能机构，机构箱内有合闸单元、一个或几个线圈组成的分闸单元、辅助开关、指示装置等部件；前方设有合分闸按钮、手动储能操作孔、弹簧储能状态指示牌、合分闸指示牌。

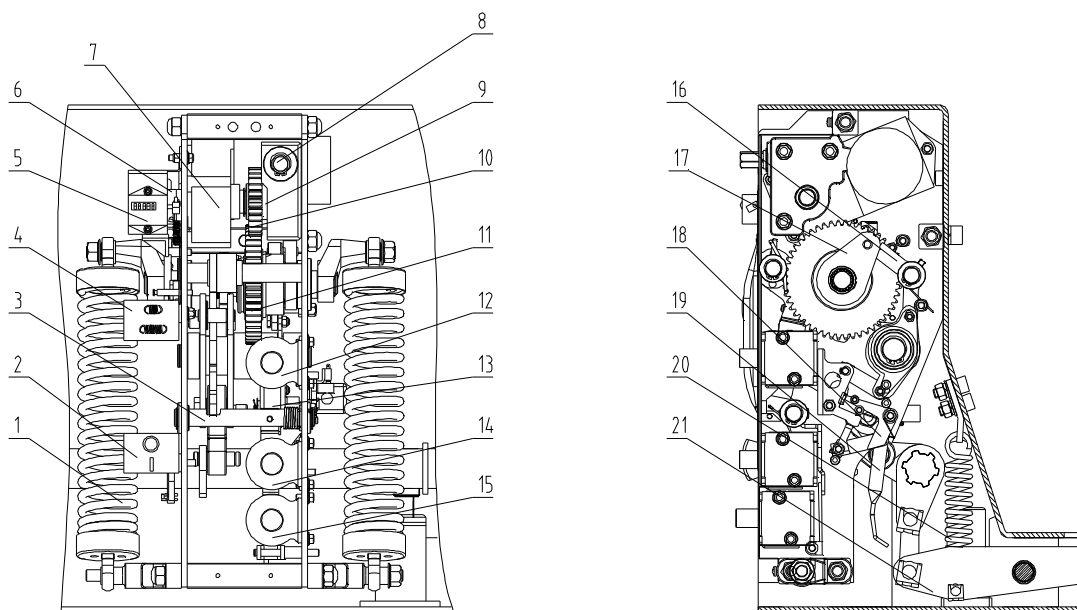

- | | | | |
|------------|-----------|-----------------|-----------|
| 1. 合闸弹簧 | 2. 合分闸指示牌 | 3. 分闸半轴 | 4. 储能指示牌 |
| 5. 计数器 | 6. 微动开关 | 7. 储能电机 | 8. 手动储能轴 |
| 9. 电机输出轴 | 10. 小齿轮 | 11. 大齿轮 | 12. 合闸线圈 |
| 13. 合闸板 | 14. 分闸线圈 | 15. 过流线圈或第二分闸线圈 | |
| 16. 储能保持挚子 | 17. 储能保持块 | 18. 合闸联锁板 | 19. 手车联锁板 |
| 20. 分闸簧 | 21. 输出拐臂 | | |

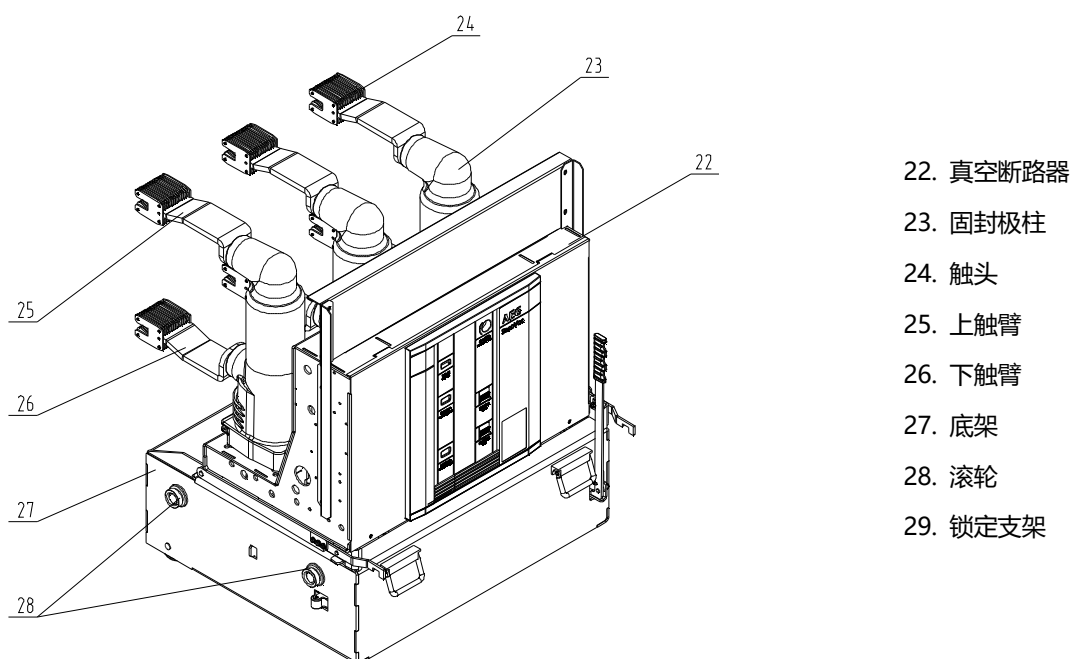

2-2-1 储能

断路器合闸所需要的能量由合闸弹簧提供。储能即可以由电机电动完成，也可以使用储能手柄手动完成。

储能操作：由固定在框架上的储能电机进行，或者将储能手柄插入手动储能轴中顺时针摇动进行。电动储能时由电机输出轴带动齿轮系统进行，手动储能时通过手动储能轴带动齿轮系统进行。小齿轮转动时，带动大齿轮一起运动，从而拉动储能弹簧进行储能。到达储能位置时，储能保持掣子顶住储能保持块，使离合器分离，保持储能位置。储能指示牌显示拉簧拉伸状态，储能完成。微动开关切断储能电机供电电源，此时断路器处于合闸准备状态。

2-2-2 合闸

在合闸过程中，不论用手动按下“合闸”按钮或远方操作使合闸线圈动作，均可使储能保持掣子脱离储能保持块，在合闸弹簧力的作用下，带动凸轮转动，凸轮又驱动连杆机构带动绝缘拉杆和灭弧室的动触头进行合闸。

合闸动作完成后分闸保持掣子与分闸半轴保持扣接状态，同时储能指示牌、辅助开关复位，电机供电回路接通。若外接电源也接通则再次进入储能状态，连杆拉动合分指示牌，指示“|”的位置，同时拉动计数器实现计数，传动连杆拉动主轴，带动辅助开关切换。

注：当断路器已处于合闸状态或选用合闸闭锁装置而未接通外接电源、手车式断路器在推进过程中时，均不能进行合闸操作。

2-2-3 分闸

既可按“分闸”按钮，也可接通外部电源使分闸线圈或过流线圈动作，使分闸保持掣子与分闸半轴解锁而实现分闸操作。由触头弹簧和分闸弹簧储存的能量使灭弧室动静触头分离。在分闸过程后段，由液压缓

冲器吸收分闸过程剩余能量并限定分闸位置。

由连杆拉动合分指示牌显示出“O”的位置，由传动连杆拉动辅助开关切换。

3.技术参数

3-1 主要技术参数

序号	项目	单位	数值	
1	额定电压	kV	12	15
2	额定连续电流	A	1200/1250/2000	1200/1250/2000
3	额定工频耐受电压 (1min)	kV	42/48	42/48
4	额定雷电冲击耐受电压		75/85	95/105
5	额定频率	Hz	50/60	50/60
6	额定短路开断电流	kA	31.5 40	31.5 40
7	额定短时开断电流 (2S)		31.5 40	31.5 40
8	额定峰值耐受电流	kA	80 100	82 104
9	额定短路关合电流		80 100	82 104
10	额定操作顺序		O-0.3s-CO-180s-CO	O-0.3s-CO-180s-CO
11	触头开距	mm	9.0±1.0	9.0±1.0
12	接触行程 (超行程)		3.5±0.5	3.5±0.5
13	平均合闸速度	m/s	0.4~0.8	0.4~0.8
14	平均分闸速度		0.9~1.3	0.9~1.3
15	合闸时间 (额定电压)	ms	30~70	30~70
16	分闸时间 (额定电压)		20~50	20~50
17	触头合闸弹跳时间	ms	≤2	≤2
18	三相分、合闸不同期		≤2	≤2
19	各相导电回路电阻	μΩ	≤45 (1200/1250A) ; ≤40 (2000A)	≤45 (1200/1250A) ; ≤40 (2000A)
20	储能时间	s	≤10	≤10
21	分级	级	E2-M2-C2	E2-M2-C2

3-2 操作机构与闭锁电磁铁的技术参数

额定电压 (V)	储能电机 (A)	合闸线圈 (A)	分闸线圈 (A)	闭锁电磁铁 (mA)
DC110	2.0	2.2	2.2	35
DC220	1.0	1.3	1.3	20

4.外形尺寸

外形尺寸见下图

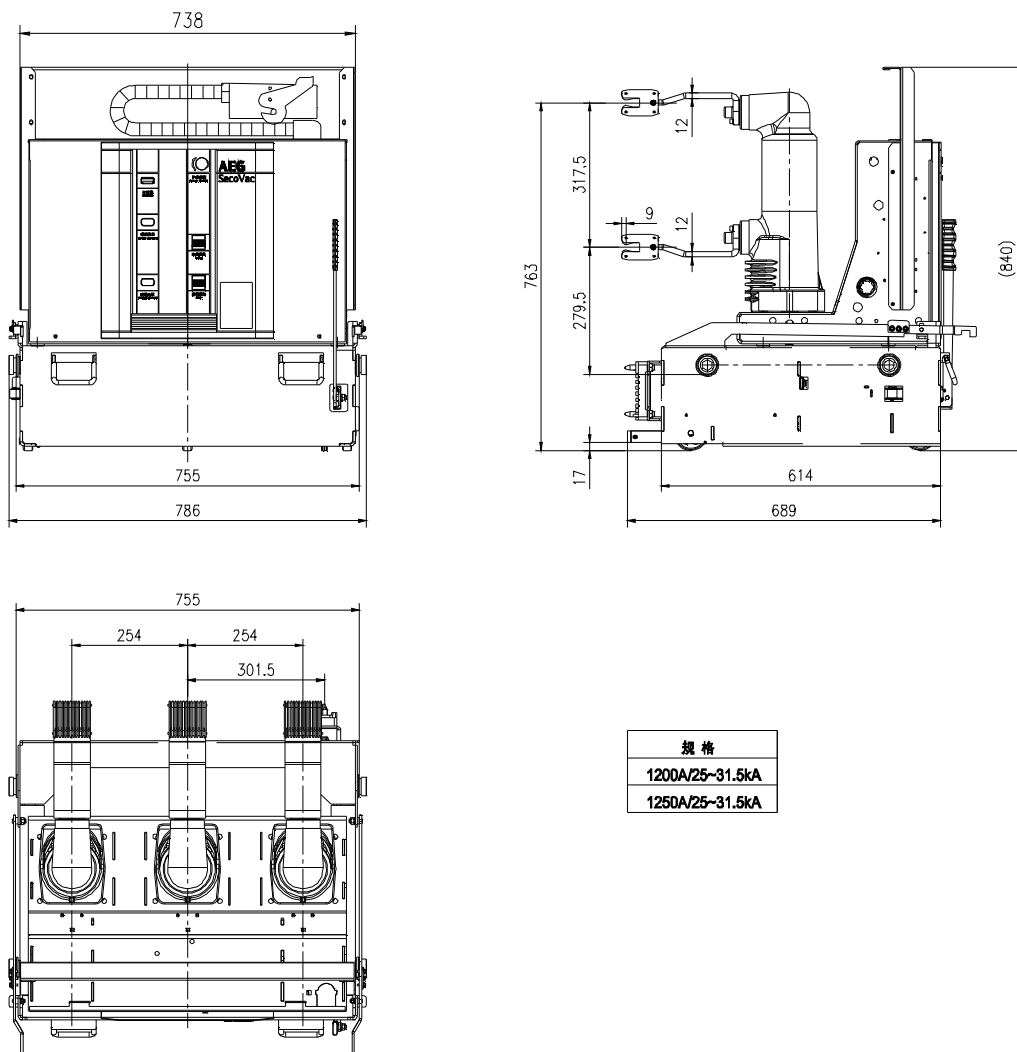

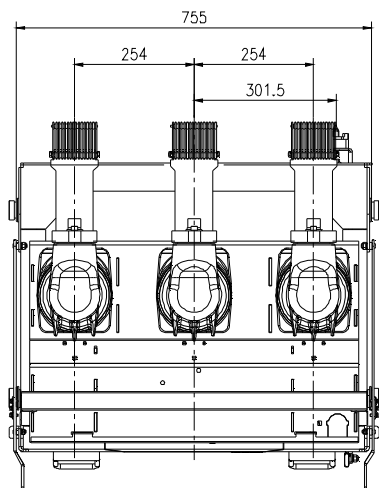
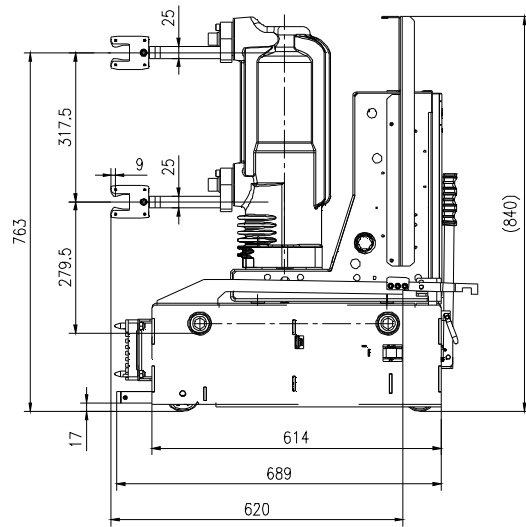
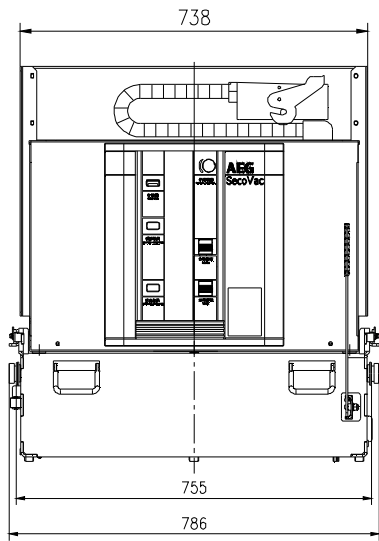

規格
1200A/40kA
1250A/40kA
2000A/31.5-40kA

5.电气原理图

断路器常规产品配备防跳，但根据用户的需要，可以选择解除防跳回路。

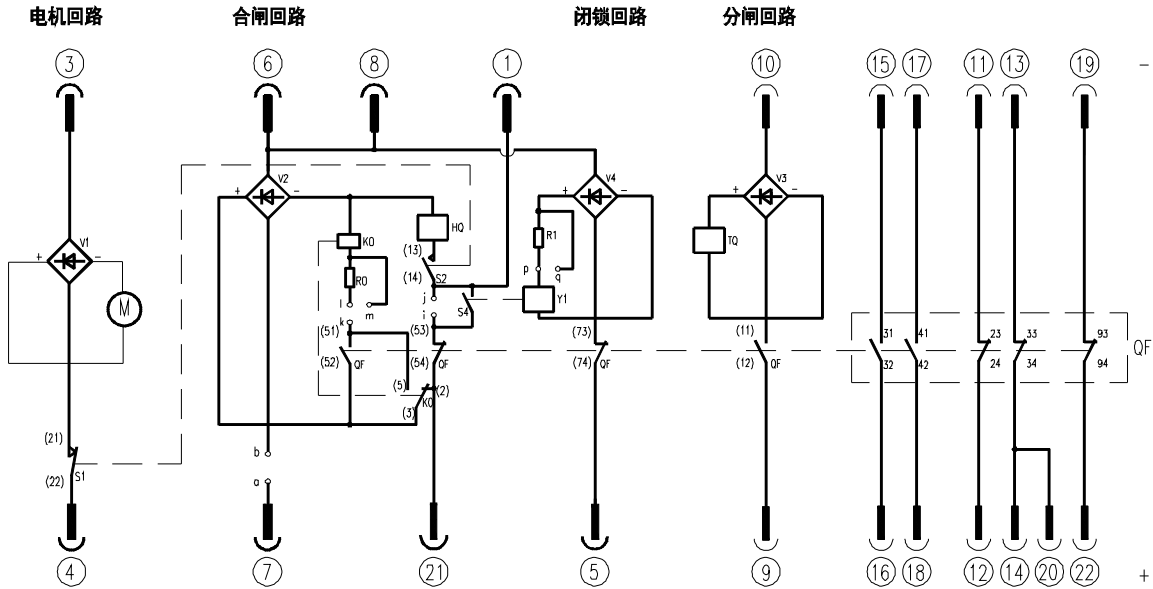

可选件接线设置:

防跳状态 配置	跳线	跳线		
		a-b	l-j	l-k
带防跳	带闭锁	✓	/	✓
	无闭锁	✓	✓	✓
无防跳	带闭锁	✓	/	/
	无闭锁	✓	✓	/

操作电源选择:

操作电源	跳线	
	p-q	m-l
AC/DC 220V	✓	/
AC/DC 110V	✓	✓

注: "/ " 表示断开; "✓" 表示连接。

S4: 闭锁电磁铁的辅助开关	HQ: 合闸线圈	V1~V4: 整流器
S1~S3: 储能用微动开关	TQ: 分闸线圈	KO: 机构内部防跳继电器(可选)
QF: 辅助开关	R0~R1: 电阻	Y1: 闭锁电磁铁(可选)
M: 储能电机	a~q: 跳线端子	

6.安装、调试与操作

6-1 断路器从包装箱中起吊时，挂钩应挂在断路器上有起吊标志的起吊位置处。移动时不得使上、下出线臂受力，同时不应让断路器受到较大的冲击震动。

6-2 安装在开关柜中的断路器不应受到拉力或变形，在底部安装点的螺栓需加碟形弹簧垫片。连接主接线端时，不能使主接线端受到（如受母线等）永久性的拉力，压力。连接母线时，需用强度为≥8.8级的螺栓，并使用碟形弹簧来紧固母线。

6-3 如在操作中遇到问题，先按照下表确定原因。如不能解决，请与制造厂联系，切勿自行对断路器拆装。

序号	现象	可能产生的原因
1	不能合闸	1.已处于合闸位置状态
		2.手车式断路器未完全进入工作位置或试验位置
		3.选用了合闸闭锁电磁铁，而辅助电源未接通或低于技术要求
		4.二次线路不正确
2	不能摇进摇出	1.断路器处于合闸状态
		2.推进手柄未完全插入推进孔
		3.推进机构未完全到达试验位置，致使舌板不能与柜体解锁
		4.与柜体接地联锁未解除

6-4 调试与操作中的各项工作应由受过专门培训、详细了解本断路器性能的人员进行。工作中必须考虑相应的保护和预防措施。

无故障操作前提之一是按GB/T 1984和IEC 60694标准相应的规定，在正常工作条件下使用断路器。

- 检查断路器有无损坏或任何其它有危害性的环境影响。若有此现象，通电前应先排除以恢复到正常的工作条件。
- 清除污垢，尤其是绝缘件表面的脏污。这些可能是由于在运输或储存过程造成的脏污会影响产品绝缘性能。
- 检查一次回路接触、二次回路连接和接地体的连接状态。
- 手动操作试验。

7.维护与保养

必须由AEG公司人员或对本设备熟悉并经培训合格的用户方人员进行维修。如由用户方人员进行维修，则由用户方承担相应维修后果责任。

7-1 在正常使用期间，断路器免维护。由于断路器具有结构简单和耐用的特点，因此有很长的使用寿命。维护工作与零部件受磨损和老化情况有关。为使断路器可靠工作，所需进行的维护工作的间隔时间和检修范围将取决于工作环境的影响、操作次数、运行时间以及短路电流开断的次数等诸因数。

7-2 在进行维护工作前，所有的辅助电源均必须断开且没有再送电的危险。断路器本身处于分闸且弹簧未储能状态。为防止意外事故，在对操作机构上进行的各项工作应格外小心。

7-3 拆卸和更换断路器零部件，应由AEG公司人员或相应的受过培训的人员来实施，特别是在重新装配期间，需做必要的调整。

7-4 断路器维护保养

a. 在运行满5年时（从新设备投入运行开始日计）或断路器操作规定次数（31.5kA断路器在操作满4000次、40kA的断路器在操作满2500次）时需对操作结构进行检查：

- 切断储能电源，操作断路器合、分闸各一次以使机构释能。
- 检查滚动或滑动轴承表面的润滑脂情况
- 在电气和机械动作时检查各个元件功能的正确性。
- 做全面外观检查。

b. 在运行满10年时（从新设备投入运行开始日计）或断路器操作规定次数（31.5kA断路器在操作满8000次、40kA的断路器在操作满5000次）时需对操作结构进行维护：

- 切断储能电源，操作断路器合、分闸各一次以使机构释能。
- 对支撑轴、滚动和滑动轴承等需要润滑部位重新涂抹润滑脂。
- 在电气和机械动作时检查各个元件功能的正确性。
- 检查连杆、拐臂、支杆等处安装的紧固件状况或有无松动现象。
- 维护时应重点检查在运行中受到大应力作用的部件。

如有更换零部件重新装配设备时，应更换所有的紧固件。

全面复查操作机构。

7-5 在断路器运行了约5年之后或当操作机构进行维护时，也应对断路器本体进行检查。尤其是检查外观情况的同时，也需检查设备表面的污秽、受潮及腐蚀情况。用干布清洁绝缘件表面的灰尘，然后用粘有家用碱性清洗剂或安全清洗剂的绸布揩去各种污秽物（应注意所使用的清洁剂是否适用于塑料和合成橡胶材），不得使用四氯化碳或三氯乙烯去清揩。

在一些特殊使用场合或有损害的环境条件下运行的开关设备（如在高污秽和重腐蚀性气体的环境条件中），上述检查工作的最短间隔时间应小于5年。

8.运输与储存

8-1 产品运输时，断路器应处于分闸且弹簧未储能的状态下装入封闭的包装箱内加以固定，内置适量干燥剂。断路器应用塑料薄膜加以保护，以防在装卸时渗入水和在存储时侵入灰尘。

8-2 装卸包装箱应采用以下工具

- 起重机
- 叉车
- 行车

8-3 运输途中应注意如下事项：

- 避免冲击
- 避免其它破坏性的机械力
- 起吊器具不应搭钩在断路器本体或操作机构上。而应搭钩在断路器有起吊标志的起吊位置上。

8-4 断路器储存须处于操作机构分闸、储能弹簧未储能状态。

储存基本要求

- 干燥且通风良好的储存室，气候条件符合GB/T 1984、IEC 60694的有关规定。
- 储存室温度不低于-25°C。
- 不要拆卸或损坏包装物。用保护性的轻质覆盖物遮盖，并保持足够的空气流通。

- 定期检查是否有凝露现象等不适宜储存要求的状况。

9.随机文件

- 产品合格证
- 出厂检验报告
- 装箱单

10.备品备件

当用户需要时，可按照下述清单确定所需备件，并在订货时提出，以备不时之需。

订货号 (SAP)	产品型号
26490381	合闸闭锁电磁铁 110V (S4)
26490780	合闸闭锁电磁铁 220V (S4)
26490463	合分闸控制线路板 (需注明: 操作电压、有无防跳、有无闭锁)
26490092	合分闸辅助开关 (QF)
26490580	储能微动开关 (S1、S2、S3)
26400055	合分闸线圈 (110V)
26400054	合分闸线圈 (220V)
26490375	断路器储能电机 (110V)
26490359	断路器储能电机 (220V)
26490349	断路器摇进手柄
26490365	机构储能手柄头

Caution!

Please read this manual carefully before installing and using the circuit breaker:

The installation and use of circuit breakers must comply with the requirements of this manual.

Circuit breaker should be used in accordance with the normal indoor environmental conditions.

Any operation and maintenance of the circuit breaker should be carried out by professional trained full-time electrical personnel.

It is forbidden to operate the circuit breaker beyond its rated parameters.

Attention must be paid to any identification of circuit breakers.

It is necessary to ensure the applicability and safety of interlocking conditions and working procedures of circuit breakers.

It is not allowed to carry out maintenance work when the switch cabinet and secondary control circuit are charged.

It must be ensured that the circuit breaker is not impacted by any external force, otherwise the equipment will be damaged.

Any illegal operation of the circuit breaker may damage the equipment and even cause serious accidents.

This manual should be placed in a convenient place.

Professional personnel should be responsible for the safety management of circuit breakers.

Contents

1. Overview	13
2. Structural principle.....	14
3. Technical parameter	17
4. Dimensions	18
5. Electrical schematic diagram.....	20
6. Installation, commissioning and operation.....	20
7. Maintenance.....	21
8. Transportation and storage	23
9. Random documents.....	23
10. Spare parts.....	24

1. Overview

1-1 General:

VB1 Plus vacuum circuit breaker (hereinafter referred to as circuit breaker) is suitable for indoor switchgear components with air insulation, and can be used to replace the original VB1 circuit breaker switchgear in AC power systems with a maximum rated voltage of 15kV.

1-2 General provisions:

VB1 Plus breaker complies with the following standards:

GB/T 1984	High-voltage alternating-current circuit-breakers
IEC 62271-100	High-voltage switchgear and controlgear - Part 100: Alternating current circuit-breakers
IEC 60694	Common specifications for high-voltage switchgear and controlgear standards
IEEE C37.59-2018	IEEE standard for requirements for conversion of power switchgear equipment - redline
IEEE C37.04-2018	IEEE standard for ratings and requirements for AC high-voltage circuit breakers with rated maximum voltage above 1000 V
IEEE C37.06-2017	IEEE recommended practice for preferred ratings for high-voltage (>1000 volts) AC circuit breakers designated definite purpose for fast transient recovery voltage rise times
IEEE C37.20.2-2015	IEEE standard for metal-clad switchgear
IEEE C37.09-2018	IEEE standard test procedures for AC high-voltage circuit breakers with rated maximum voltage above 1000 V
IEEE C37.100	IEEE standard for common requirements for high-voltage power switchgear rated above 1000 V
DL/T 403	HV vacuum circuit-breaker for rated voltage 12kV to 40.5kV

1-3 Normal operating conditions:

Ambient temperature

Maximum temperature: + 40°C

Minimum temperature: - 25°C

Maximum daily average temperature: + 35°C

Ambient humidity

Daily average relative humidity: ≤95%

Monthly average relative humidity: ≤90%;

Daily average saturated vapor pressure: ≤2.2×10⁻³ Mpa

Monthly average saturated vapor pressure: ≤1.8×10⁻³ Mpa

Altitude: ≤ 1000m, conventional products can be used below 1000m above sea level, and high-altitude products need to be noted when ordering.

Earthquake intensity: No higher than Level 8

Others: no inflammable and explosion hazard, no chemical corrosive gas and no violent vibration.

Note: in case of different use environment or other special requirements, it is necessary to consult with the manufacturer.

2. Structural principle

2-1 Main structure

The conductive circuit of the circuit breaker is a fixed structure, and the conductive circuit is set in the insulating parts. This structure can effectively prevent the influence of external factors such as external force impact and pollution environment on the vacuum interrupter. The conductive circuit of the circuit breaker is installed at the back of the mechanism box and connected with the mechanism as a whole.

Primary circuit current route: when breaker is at the closing position, current flow from the upper terminal to the upper bracket, which is fixed in the arc quenching chamber, then into the vacuum interrupter contacts, the movable contact, and connection of conductive clips, soft connection, to the lower terminal, the insulating pull rod and the internal disc spring pass through the connecting rod of the circuit breaker to complete the operation movement of the circuit breaker and keep the contact.

2-2 Operating mechanism

The operating mechanism of the circuit breaker is a spring energy storage mechanism. There are closing unit, opening unit composed of one or several coils, auxiliary switch, indicating device and other components in the mechanism box; the front is provided with closing and opening button, manual energy storage operation hole, spring energy storage status indicator board and closing and opening indicator board.

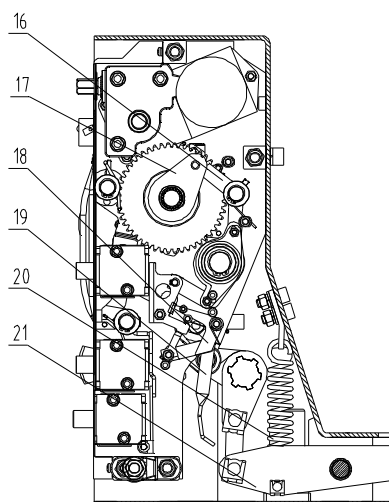
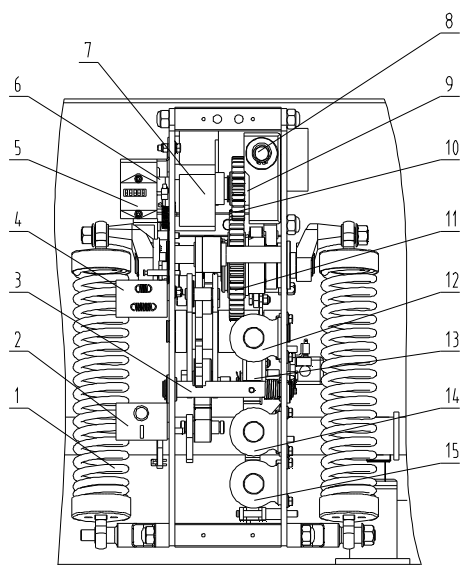

- | | | |
|----------------------------------|------------------------------|---|
| 1. Closing spring | 2. closing/opening indicator | 3. opening latch |
| 4. charging indicator | 5. counter | 6. micro-switch |
| 7. charging motor | 8. manual charging shaft | 9. motor output shaft |
| 10. small gear | 11. large gear | 12. closing coil |
| 13. closing plate | 14. opening coil | 15. over-current coil/secondary tripping coil |
| 16. energy storage keeping block | 17. energy storage latch | 18. closing interlock block |
| 19. handcart interlock block | 20. opening spring | 21. output arm |

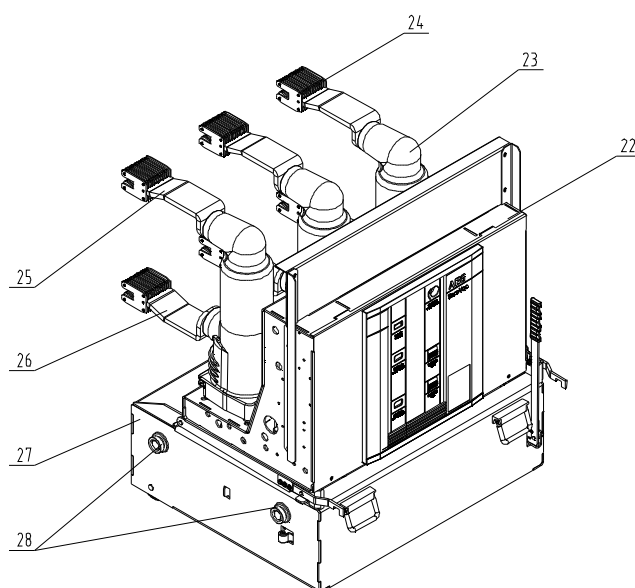

- 22. Vacuum Circuit Breaker
- 23. Embedded pole
- 24. contact
- 25. Uppercontact arm
- 26. Lower contact arm
- 27. Chassis
- 28. contact roller
- 29. Locking bracket

2-2-1 Energy storage

The energy required for closing the circuit breaker is provided by the closing spring. Energy storage can be done either by motor or by hand with energy storage handle.

Energy storage operation: it is carried out by the energy storage motor 7 fixed on the frame or by inserting the energy storage handle into the manual energy storage shaft 8 and shaking it clockwise. The gear system is driven by motor output shaft 9 for electric energy storage, and the gear system is driven by manual energy storage shaft 8 for manual energy storage. When the small gear rotates, it drives the big gear to move together, thus pulling the energy storage spring to store energy. When the energy storage position is reached, the energy storage holding block is supported by the energy storage holding block to separate the clutch and maintain the energy storage position. The energy storage indicator board shows the tension state of the tension spring, and the energy storage is completed. The micro switch cuts off the power supply of the energy storage motor, and the circuit breaker is in the closing ready state.

2-2-2 Closing

During the closing process, whether manually pressing the "closing" button or remote operation to

make the closing coil 12 act, the energy storage holding device can be turned away from the energy storage holding block. Under the action of the closing spring force, the cam drives the cam to rotate, and the cam drives the connecting rod mechanism to drive the insulating rod 23 and the moving contact of the arc extinguishing chamber to close.

After the closing action is completed, the opening holding switch and the opening half shaft are kept in the buckle state. At the same time, the energy storage indicator board and auxiliary switch are reset, and the motor power supply circuit is connected. If the external power supply is also connected, it will enter the energy storage state again, and the connecting rod will pull the on / off indicator to indicate the position of " | ", at the same time, pull the counter to realize counting, and drive the connecting rod to pull the spindle to drive the auxiliary switch to switch.

Note: when the circuit breaker is in the closing state, or the closing locking device is selected but the external power supply is not connected, and the handcart type circuit breaker is in the process of propulsion, the closing operation cannot be carried out.

2-2-3 Opening

It can not only press the "opening" button, but also connect the external power supply to make the opening coil or over-current coil act, so that the opening holding switch and the opening half axis are unlocked to realize the opening operation. The energy stored by the contact spring and the opening spring 25 separates the dynamic and static contacts of the arc extinguishing chamber 21. In the later stage of the opening process, the hydraulic buffer absorbs the residual energy and limits the opening position.

Pull the "O" connecting rod to switch off the switch.

2-2-4 Undervoltage protection function

When the secondary control voltage is less than or equal to 90% of the rated voltage, the undervoltage module must start to store energy for components and enter the holding state; when the secondary control voltage drops to 65% of the rated voltage, the energy of the undervoltage module is released to the opening coil of the circuit breaker to release the opening holding switch and the opening half shaft So as to realize the opening operation.

2-3 Anti misoperation interlock

The circuit breaker can provide perfect anti misoperation function

1. After the closing operation of the circuit breaker is completed, the closing interlocking board 18 rotates against the closing board 13, and it cannot be closed again when the circuit breaker is not opened.

2. After closing the circuit breaker, if the closing electric signal is not removed in time, the internal anti tripping controller of the circuit breaker will cut off the closing circuit to prevent multiple reclosing.

3. When the handcart type circuit breaker fails to reach the test position or working position, the handcart interlocking board 19 shall buckle the closing board and cut off the closing circuit to prevent the circuit breaker from entering the load area in the closing state.

4. After the handcart type circuit breaker is closed in the working position or test position, the trolley will not be able to move if the roller presses the pushing mechanism, so as to prevent pulling out or pushing the load area in the closing state.

5. If electrical closing locking is selected, manual closing operation is prevented when the secondary control power supply is not connected.

3. Technical parameter

3-1 Main technical parameter

No.	Item	Unit	Value	
1	Rated voltage	kV	12	15
2	Rated normal current	A	1200/1250/2000	1200/1250/2000
3	Rated power frequency withstand voltage (1 min)	kV	42/48	42/48
4	Rated lightning impulse withstand voltage		75/85	95/105
5	Rated frequency	Hz	50/60	50/60
6	Rated short-circuit breaking current	kA	31.5 40	31.5 40
7	Rated short-time withstand current(2s)		31.5 40	31.5 40
8	Rated peak withstand current	kA	80 100	82 104
9	Rated short-circuit making current		80 100	82 104
10	Rated operation procedure		O-0.3s-CO-180s-CO	O-0.3s-CO-180s-CO
11	Contact distance	mm	9.0±1.0	9.0±1.0
12	Contact travel		3.5±0.5	3.5±0.5
13	Average closing speed	m/s	0.4~0.8	0.4~0.8
14	Average opening speed		0.9~1.3	0.9~1.3
15	Closing time (rated voltage)	ms	30~70	30~70
16	Opening time (rated voltage)		20~50	20~50
17	Closing bounce time	ms	≤2	≤2
18	Three-phase opening/closing		≤2	≤2
19	Main loop resistance	μΩ	≤45 (1200/1250A) ; ≤40 (2000A)	≤45 (1200/1250A) ; ≤40 (2000A)
20	Energy storage time	s	≤10	≤10
21	Classification	class	E2-M2-C2	E2-M2-C2

3-3 Technical parameters of operating mechanism and locking electromagnet

Rate voltage (V)	Energy storage motor (A)	Closing coil (A)	Opening coil (A)	Lockout electromagnet (mA)
DC 110	2.0	2.2	2.2	35
DC 220	1.0	1.3	1.3	20

4. Dimensions

The overall dimensions are shown in the figure below.

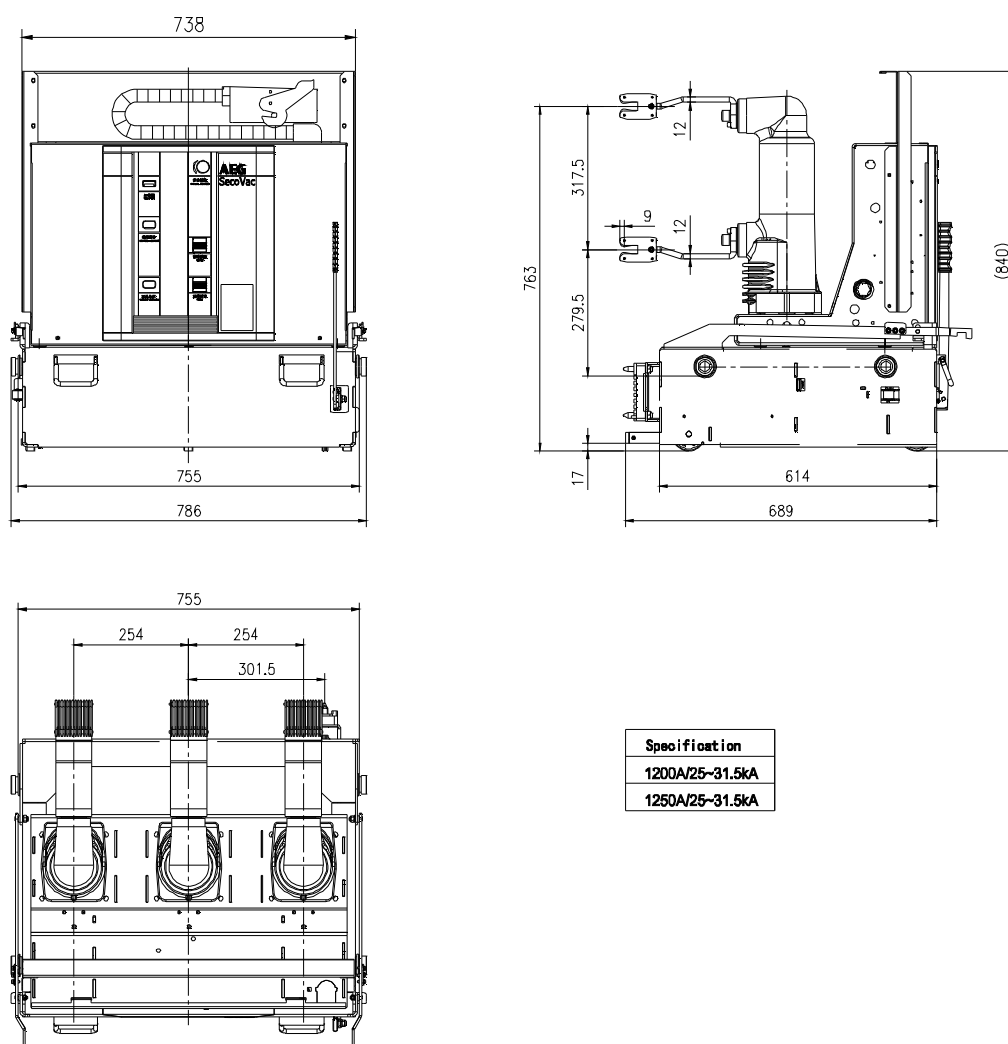

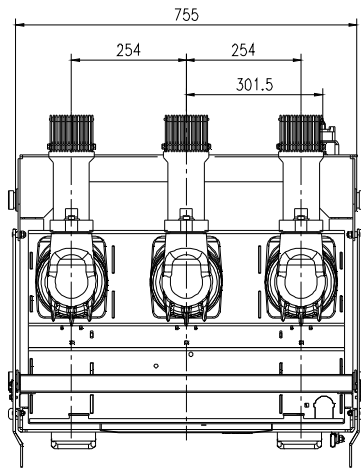
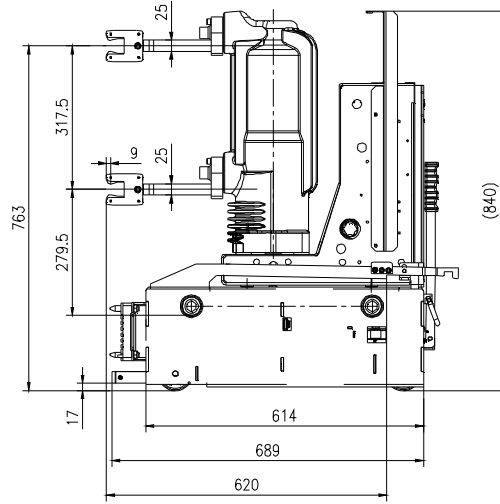
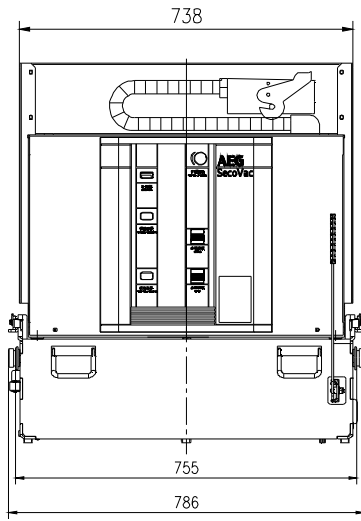

Specification
1200A/40kA
1250A/40kA
2000A/31.5~40kA

5. Electrical schematic diagram

Conventional circuit breaker products are equipped with anti-trip circuit, but according to the needs of users, the anti-tripping circuit can be removed.

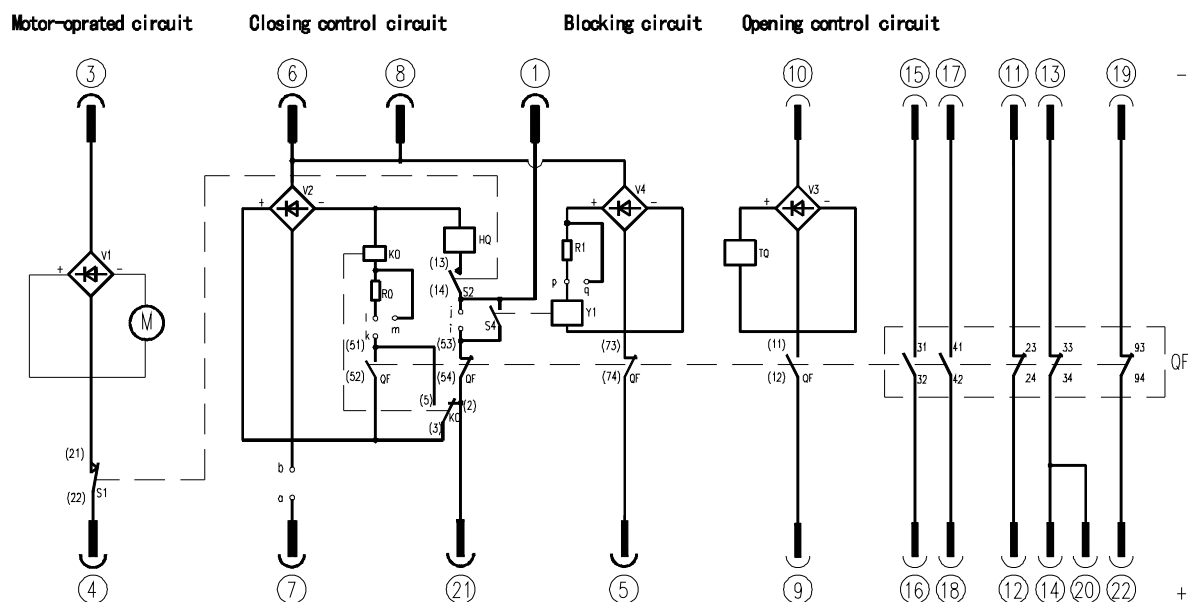

Option	Jumper wire	a-b	l-j	l-k
■ Anti-pumping relay	■ Blocking coil I	■	□	■
	□ Blocking coil II	■	■	■
□ Anti-pumping relay	■ Blocking coil I	■	□	□
	□ Blocking coil II	■	■	□

Option	Jumper wire	p-q	m-l
■ AC/DC 220V		■	□
■ AC/DC 110V		■	■

Remarks:

1. Shown with the stored-energy spring in the discharged, the breaker in open and test position.
2. The light grey terminal must be the same pole in DC control voltage.

S4: Auxiliary switch for blocking coil	H0: Closing coil	M: Energy-storage motor
S1/S3: Energy storage position switch	T0: Opening coil	OF: Auxiliary switch of closing/opening operation
K0: Anti-pumping relay (optional)	R0/R1: Resistance	V1~V4: Rectifier

6. Installation, commissioning and operation

6-1 When the circuit breaker is lifted from the packing box, the hook shall be hung on the lifting position with lifting mark on the circuit breaker. When moving, the upper and lower outlet arms shall not be stressed, and the circuit breaker shall not be subject to large impact and vibration.

6-2 The circuit breaker installed in the switch cabinet shall not be subject to tension or deformation, and the bolt at the bottom mounting point shall be added with disc spring gasket. When connecting the main terminal, the main terminal shall not be subject to permanent tension and pressure (such as the bus bar). When connecting the bus, bolts with strength ≥ 8.8 and disc spring are used to fasten the bus.

6-3 In case of problems in operation, determine the causes according to the table below. If it can't be solved, please contact the manufacturer. Do not disassemble the circuit breaker by yourself.

No.	Fault phenomena	Reasons
1	Failure to closing	1. The breaker is in the closing position state
		2. The handcart does not fully come into operation position or test position
		3. The closing locking device is employed and the auxiliary supply is unconnected or lower than the specifications
		4. secondary circuit is incorrect
2	The handcart cannot be pushed in or pulled out	1 The breaker is in the closing position state
		2 The pushing- handle is not fully inserted into the pushing hole.
		3. The pushing mechanism is not fully placed at the test position, so that the clapper cannot be unlocked with the cabinet body
		4. The cabinet body earthing interlocking is not released

6-4 The commissioning and operation work shall be carried out by specially trained personnel who have a detailed understanding of the performance of the circuit breaker. The corresponding protection and prevention measures must be considered in the work.

One of the preconditions for trouble free operation is to use the circuit breaker under normal working conditions according to the corresponding provisions of GB/T 1984 and IEC 60694 standards.

- check the circuit breaker for damage or any other harmful environmental impact. If there is such a phenomenon, it should be eliminated before power on to restore to normal working conditions.
- Remove dirt, especially on the surface of insulating parts. These may be due to contamination during transportation or storage, which may affect the insulation performance of the product.
- check the connection status of primary circuit contact, secondary circuit connection and grounding body.
- Manual operation test.

7. Maintenance

Maintenance must be carried out by AEG personnel or the user's personnel who are familiar with the equipment and have been trained and qualified. If the maintenance is carried out by the user's personnel, the user shall be responsible for the consequences of the repair.

7-1 During normal use, the circuit breaker is free of maintenance. Because the circuit breaker has the characteristics of simple structure and durability, it has a long service life. The maintenance work is related to the wear and aging of parts. In order to make the circuit breaker work reliably, the interval time and range of maintenance work needed to be carried out will depend on the influence of working environment, operation times, operation time and short circuit current breaking times and other factors.

7-2 Before maintenance, all auxiliary power supply must be disconnected and there is no danger of power transmission again. The circuit breaker itself is open and the spring is not stored energy. In order to

prevent accidents, special care should be taken in the operation mechanism.

7-3 Disassembly and replacement of circuit breaker parts shall be carried out by AEG personnel or corresponding trained personnel, especially during reassembly, necessary adjustment shall be made.

7-4 Maintenance of circuit breaker

a. The operation structure shall be inspected when the circuit breaker has been operated for 5 years (from the day when the new equipment is put into operation) or when the circuit breaker operates for the specified times (4000 times for the circuit breaker with 31.5kA, and 2500 times for the circuit breaker with 40kA):

- Cut off the energy storage power supply and operate the circuit breaker to close and open once to release energy.
- Check the grease condition of rolling or sliding bearing surface.
- Check the correctness of each component function during electrical and mechanical action.
- Do a comprehensive appearance inspection.

b. The operation structure shall be maintained after 10 years of operation (calculated from the day when the new equipment is put into operation) or the operation times of the circuit breaker (31.5 kA circuit breaker for 8000 times, 40 kA circuit breaker for 5000 times):

- Cut off the energy storage power supply and operate the circuit breaker to close and open once to release energy.
- Re apply grease to supporting shaft, rolling and sliding bearing.
- Check the correctness of each component function during electrical and mechanical action.
- Check the condition or looseness of fasteners installed at connecting rod, crank arm and supporting rod.
- During maintenance, it is important to check the parts which are subjected to high stress during operation.

In case of replacement of parts, all fasteners shall be replaced.

Comprehensive review of operating mechanism.

7-5 After the circuit breaker has been running for about 5 years or when the operating mechanism is under maintenance, the circuit breaker body should also be inspected. Especially when inspecting the appearance, it is also necessary to check the contamination, damp and corrosion of the equipment surface. Clean the dust on the surface of insulating parts with dry cloth, and then wipe all kinds of dirt with silk cloth with household alkaline cleaning agent or safety cleaner (pay attention to whether the detergent used is applicable to plastic and synthetic rubber materials), and do not use carbon tetrachloride or trichloroethylene to wipe.

The minimum interval of the above inspection work shall be less than 5 years for the switchgear operating in some special use occasions or under harmful environmental conditions (such as in the environment with high pollution and heavy corrosive gas).

8. Transportation and storage

8-1 When the product is transported, the circuit breaker shall be placed in a closed packing box without energy storage, and a proper amount of desiccant shall be built in. The circuit breaker shall be protected with plastic film to prevent water penetration during loading and unloading and dust intrusion during storage.

8-2 The following tools shall be used to load and unload the packing box

- Crane
- Forklift
- Driving

8-3 Pay attention to the following items during transportation:

- Avoid shocks
- Avoid other destructive mechanical forces
- The lifting appliance should not be hooked on the circuit breaker body or operating mechanism. It should be hooked at the lifting position with lifting mark.

8-4 The circuit breaker shall be stored in the state of opening of operating mechanism and energy storage spring without energy storage.

Basic storage requirements

- The dry and well ventilated storage room shall meet the relevant provisions of GB /T 1984 and IEC 60694.
- The temperature of the storage room shall not be lower than -25 ° C.
- Do not disassemble or damage the package. Cover with a protective light covering and maintain adequate ventilation.
- Regularly check whether there is condensation phenomenon and other conditions not suitable for storage requirements.

9. Random documents

- a. Product certificate
- b. Factory inspection report
- c. Packing list

10. Spare parts

When the user needs, the spare parts can be determined according to the following list, and put forward when ordering, so as to meet the needs.

Order number (SAP)	Product model
26490381	Closing locking electromagnet 110V (S4)
26490780	Closing locking electromagnet 220V (S4)
26490463	Closing/opening control circuit board (please mention: operation voltage, whether there is anti-tripping, whether there is locking)
26490092	Closing/opening auxiliary switch (QF)
26490580	Energy storage position switch (S1, S2, S3)
26400055	Closing/Opening coil (110V)
26400054	Closing/Opening coil (220V)
26490375	12kV breaker energy-saving motor (110V)
26490359	12kV breaker energy-saving motor (220V)
26490349	Pushing handle for withdrawable-type breaker
26490365	Mechanism energy-saving handle

AEG

官方网址: www.aeg-imc.com

热线电话: 400-820-5234

手册如有修改, 恕不另行通知

版本号: 2026IM3901



AEG is a registered trademark used under license from AB Electrolux (publ).